

TOP VIEW

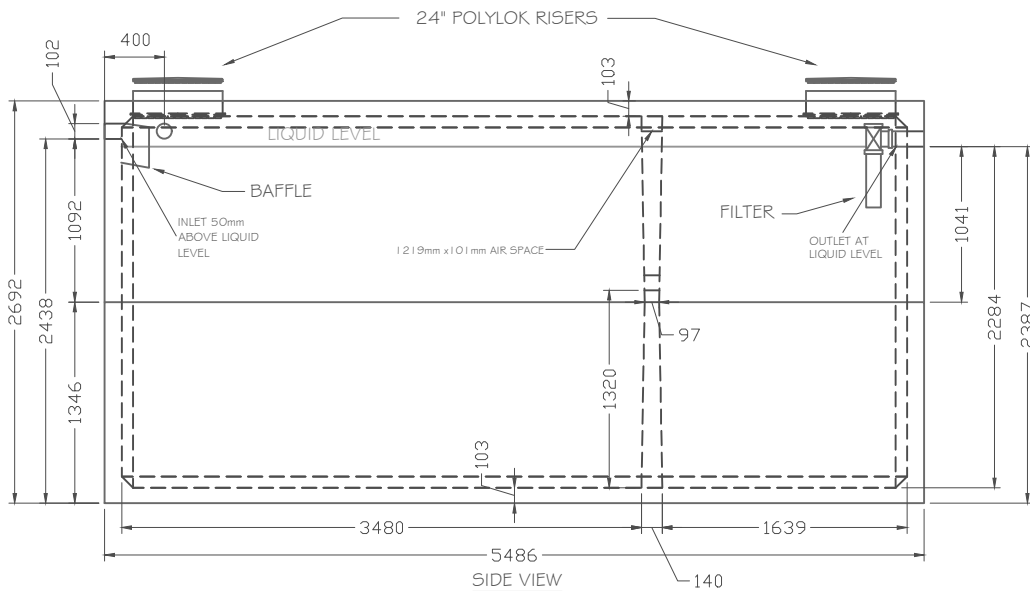

SIDE VIEW

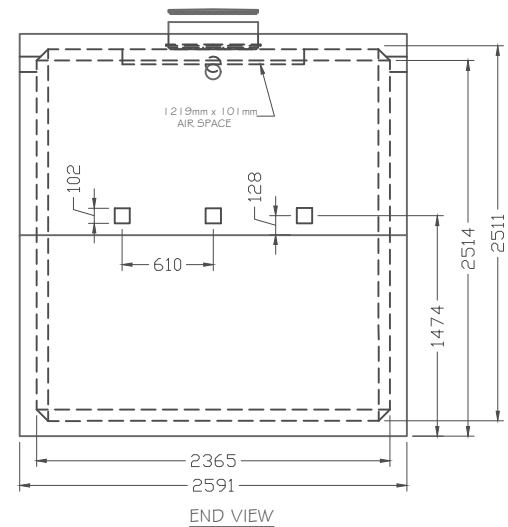

END VIEW

GENERAL:
 ALL DIMENSIONS IN MILLIMETERS
 +/- 10mm TOLERANCES ON ALL DIMENSIONS

CONCRETE:
 STANDARD
 STANDARD ACC (ACCELERATED STRIPPING)
 10 MPa @ STRIPPING STRENGTH
 35 MPa @ 28 DAYS
 C-1 EXPOSURE CLASS
 SULPHATE RESISTANT
 6.7 CUBIC YARDS (BOTTOM HALF)
 4.8 CUBIC YARDS (TOP HALF)

REINFORCING:
 ALL REINF. HAS MIN. 25mm OF COVER

TANK:
 10M @ 300mm O/C EW

LID:
 10M @ 300mm O/C EW
 CORNER BARS AROUND RISERS

WEIGHT:
 TOP SECTION APPROX. - 19,197 LBS/8726 KG
 BTM SECTION APPROX. - 19,598 LBS/8908 KG
 ASSEMBLED APPROX. - 38,795 LBS/17,634 KG

NOTES:

DIVIDER WALL IS MONOLITHIC CAST
 JOINT SEALANT IS MASTIC SEALANT (CONCEAL CS-102)
 (NSF APPROVED SEALANT AVAILABLE FOR PORTABLE
 WATER HOLDING TANKS)
 TANK ASSEMBLED ON SITE
 1.5M MAXIMUM BURIAL
 INLETS ARE 4" POLYLOK PIPE SEALS
 LID AND RISER ARE 24" DIAMETER POLYLOK



PRODUCT:
6190 GAL/28,101 L SEPTIC TANK

PRODUCT ID:
STC 6190

CONTRACTOR:

SCALE:

N.T.S

REV	DATE	INI.	DESCRIPTION
0	03/23/ 20	LP	ORIGINAL DRAWING