

DIMENSIONS:

ALL DIMENSIONS IN MILLIMETERS
+/- 10mm TOLERANCES ON DIMENSIONS

CONCRETE:

STANDARD
BARRIERS FAST SET (ACCELERATED
STRIPPING)
10 MPa STRIPPING STRENGTH
35 MPa @ 28 DAYS
C-1 EXPOSURE CLASS
1.45 CUBIC YARDS

REINFORCEMENT:

ALL REINF. HAS MIN. 25mm OF COVER
3-10M BARS:
1-IN TOP, CENTER
2-IN BOTTOM, 300mm C/C

WEIGHT:

APPROX. 5431 LBS/2469 KG

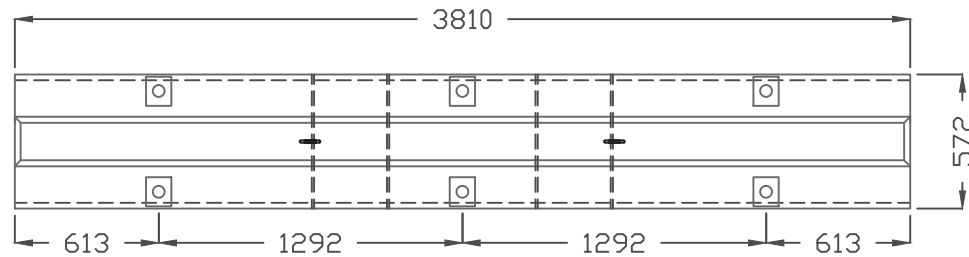

TOP VIEW

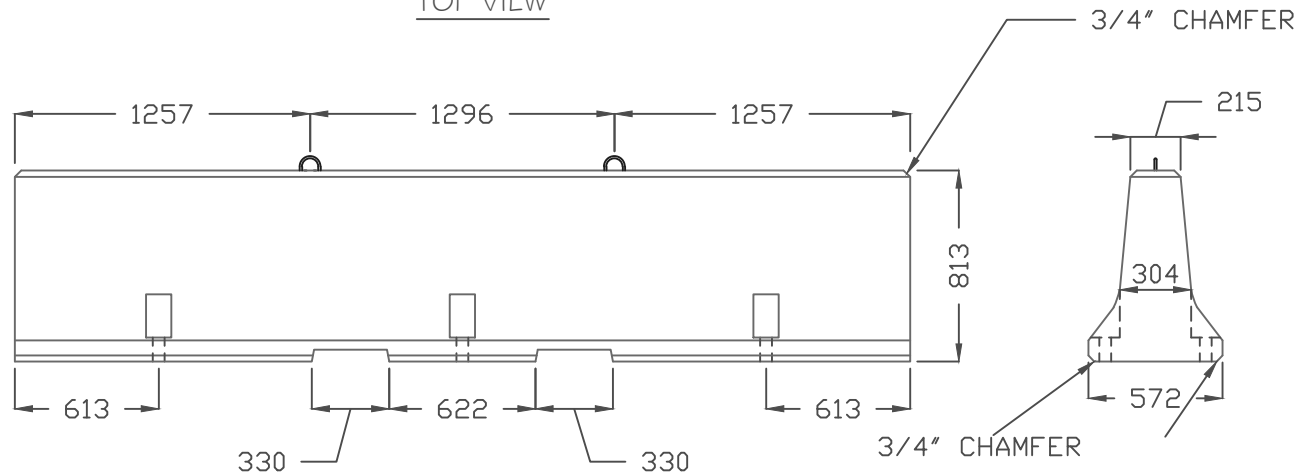

SIDE VIEW

END VIEW



58 COOPER ROAD
ROSSLYN, ONT.
Phone: (807) 939-2655
Fax: (807) 939-1788

PRODUCT

13 FOOT MEDIAN BARRIER

CONTRACTOR:

.

SCALE:

N.T.S

JOB/PRODUCT CODE:

13MBS

DATE	INI.	DESCRIPTION
21/11/13	DSM	ORIGINAL DRAWING