

TOP VIEW

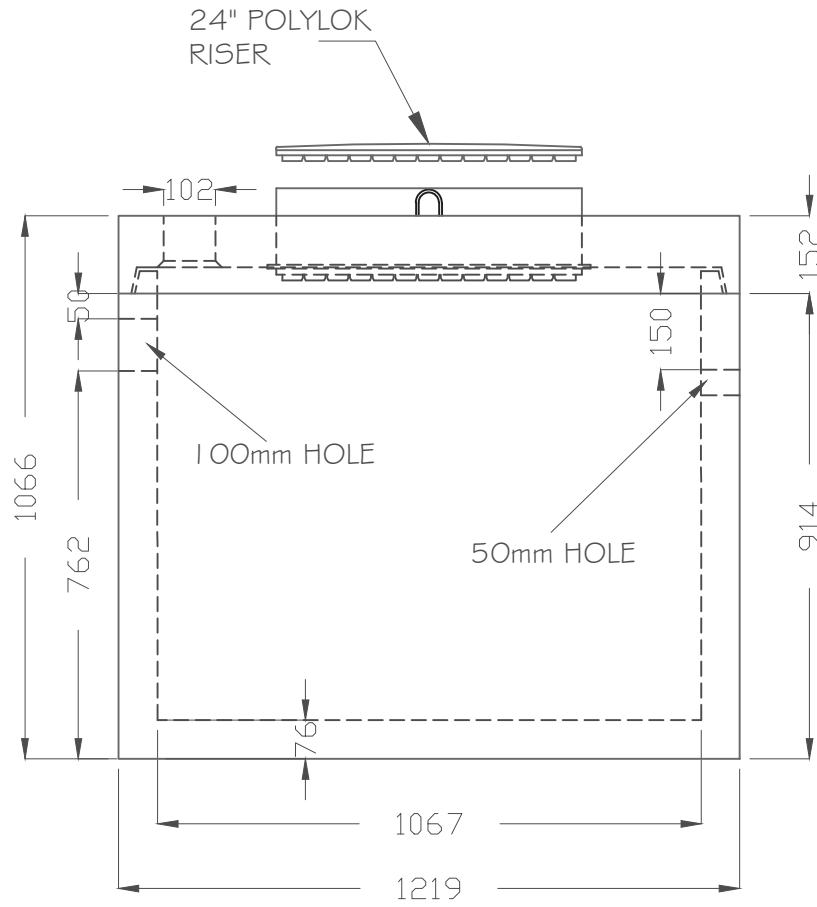

SIDE VIEW

GENERAL:
 ALL DIMENSIONS IN MILLIMETERS
 +/- 1.0mm TOLERANCES ON ALL DIMENSIONS

CONCRETE:
 STANDARD
 STANDARD ACC (ACCELERATED STRIPPING)
 10 MP_a @ STRIPPING STRENGTH
 35 MP_a @ 28 DAYS
 C-1 EXPOSURE CLASS
 SULPHATE RESISTANT

REINFORCING:
 ALL REINF. HAS MIN. 25mm OF COVER

WEIGHT:
 ASSEMBLED APPROX. - 2202 LBS/1001 KG

NOTES:
 JOINT SEALANT IS MASTIC SEALANT (CONCEAL CS-102)
 (NSF APPROVED SEALANT AVAILABLE FOR PORTABLE
 WATER HOLDING TANKS)
 TANK ASSEMBLED IN FACTORY
 1.5M MAXIMUM BURIAL
 INLETS ARE 4" POLYLOK PIPE SEALS
 LID AND RISER ARE 24" DIAMETER POLYLOK



PRODUCT:
135 GAL/615 L PUMP TANK

PRODUCT ID:
PTC 135

CONTRACTOR:

SCALE:
 N.T.S

REV	DATE	INI.	DESCRIPTION
0	03/23/ 20	LP	ORIGINAL DRAWING